

DIAMOND CUTTING TOOLS

TYPES OF DIAMOND BLADES

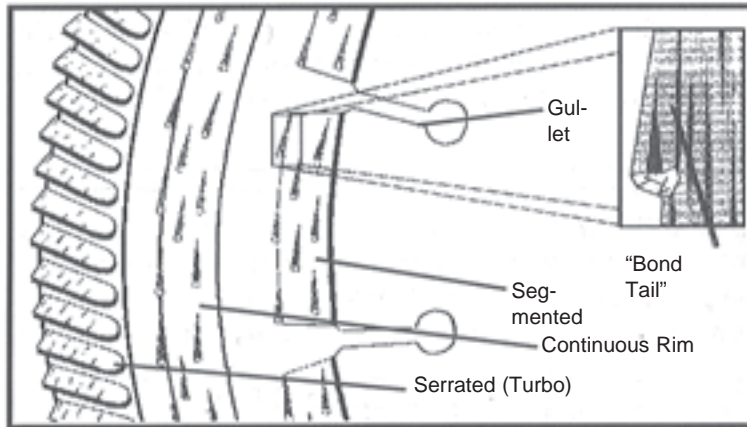

A diamond blade is a circular steel disc with a diamond bearing edge. The edge or rim can have either a segmented, continuous or serrated rim configuration.

The blade core is a precision-made steel disc which may have slots called "gullets". These provide faster cooling by allowing water or air to flow between the segments. These slots also allow the blade to flex.

Blade cores are tensioned so that the blade will run straight at the proper cutting speed. Proper tension also allows the blade to remain flexible enough to bend slightly under cutting pressure and then go back to its original position.

Diamond segments or rims are made up of a mixture of diamonds and metal powders. The diamonds used in bits and blades are man-made (synthetic) and are carefully selected for their shape, quality, friability and size. These carefully selected

diamonds are then mixed with a powder consisting of metal such as cobalt, iron, tungsten, carbide, copper and other materials. This mixture is then molded into shape and then heated at temperatures from 1700° to 2300° under pressure to form a solid metal part called the "bond" or "matrix". The segment or rim is slightly wider than the blade core. This side clearance allows the cutting edge to penetrate the material being cut without the steel dragging against the sides of the cut.

There are several methods of attaching the segments to the steel core. * Brazing - Silver solder is placed between the segment and the core and then heated until the solder melts and bonds the two together. (This method is used for wet cutting blades only). * Laser welding - The diamond segment and steel core are welded together by a laser beam. * Mechanical bond - A notched, serrated or textured blade core may be used to "lock" the diamond rim or segments onto the edge of the blade. Mechanical bonds usually also include brazing or other metallurgical bonding processes to hold the rim or segments in place.

After the blade is assembled, it is "opened", "broken in" or "dressed" by grinding the edge concentric to the center. This exposes the diamonds that will be doing the work and establishes the cutting direction as noted by the direction arrow stamped into the blade.

HOW DO DIAMOND CUTTING TOOLS WORK?

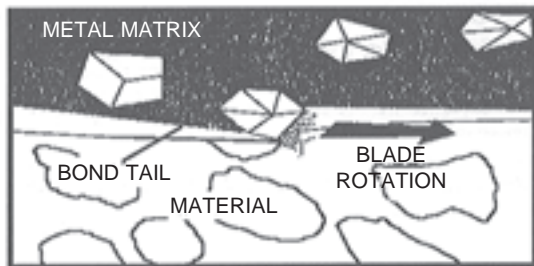

Diamond blades don't cut, they grind! The exposed diamond crystals do the grinding work. The metal matrix or bond holds the diamonds in place. Trailing behind each exposed diamond is a "bond tail" which helps to support the diamond. As the blade rotates through the material the exposed surface diamonds grind the material being cut into a fine powder.

After several thousand passes through the material being cut the exposed diamonds begin to crack and fracture. The matrix holding the diamond also begins to wear away.



Eventually the diamond completely breaks up and its fragments are swept away with the material that it is grinding.

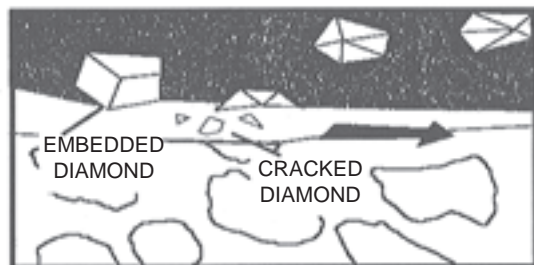

As the old diamonds are worn down they are replaced by new ones and the process continues until the blade is worn out.

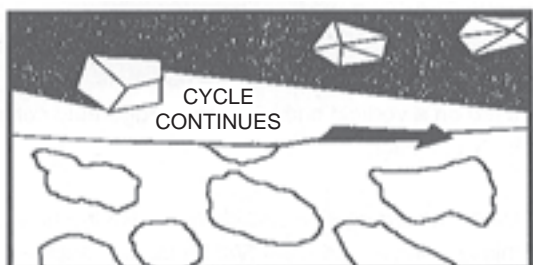

FACTORS THAT AFFECT PERFORMANCE

The following factors affect the performance of a concrete cutting blade or bit and should be considered when making your selection:

COMPRESSIVE STRENGTH

Concrete may vary greatly in compressive strength which is measured in POUNDS per SQUARE INCH (PSI). Most concrete roads are approximately 4-6,000 PSI, while typical patios and sidewalks are about 3,000 PSI.

Concrete Hardness	PSI	Application
Critically Hard	8000 +	Nuclear power plants
Hard	6-8,000	Bridge piers
Medium	4-6,000	Highways
Soft	3,000 or less	Sidewalks & patios

SIZE OF AGGREGATE

Larger aggregates tend to make a blade cut slower while smaller aggregates tend to allow a blade to cut faster. The most common aggregate sizes are:

Size	
Pea Gravel	Usually less than 3/8" in diameter
3/4"	Sieved size
1-1/2"	Sieved size

TYPE OF SAND

Sand is the component of the mix which determines the abrasiveness of the concrete. Sand can either be "sharp" (abrasive) or "round" (non-abrasive). Crushed sand or bank sand are usually sharp; river sand is usually round.

HARDNESS OF AGGREGATE

There are many different types of rock used as aggregate. Generally hard aggregate breaks down the cutting diamonds faster which means the bond must be softer to expose new diamonds. Softer aggregate generally does not break down the cutting diamonds as quickly and therefore requires a harder bond to hold the diamonds in place to use their full potential. The Mohs' scale is used to measure the hardness of aggregate and has a range of 1 - 10. Most aggregates fall into the 2 - 9 range:

Mohs' Range	Description	Aggregates
8-9	Critically hard	Flint, Chert, Trap Rock, Basalt
6-7	Hard	River Rock, Granites, Quartz, Trap Rock
4-5	Medium/Hard	Granites, River Rock
3-4	Medium	Limestone, Sand Stone, Dolomite, Marble
2-3	Soft	Soft Limestone

REINFORCING STEEL

Steel reinforcing tends to make a blade cut slower. Less reinforcing allows a blade to cut faster. Heavy rebar can also result from different grades of steel. Typical rebar is grade 40 but grade 60 is also common. Rebar gauges are in eighths of an inch. #4 is 1/2" diameter, #5 is 5/8" diameter etc.

Size	Examples
Light	Wire Mesh, single mat.
Medium	#4 rebar, every 12" on center each way (OCEW) Single mat, Wiremesh, multi-mat.
Heavy	#5 rebar, 12" OCEW, single mat. #4 rebar, 12" OCEW, double mat.

GREEN or CURED CONCRETE

The drying or curing of concrete greatly affects how the concrete will interact with a diamond blade. Green concrete is freshly poured concrete that has not yet cured. It is softer and more abrasive than cured concrete. A harder bond with undercut protection should be used in this application until it is cured at which point a softer bond would be appropriate. The definition of green concrete can vary widely. Water, temperature, moisture in the aggregate, time of year and the amount of water in the mix all influence the curing time. It is generally considered "green" for 8 to 48 hours after it has set.

VARIABLES

VARIABLES		CHANGE	RESULTS	
			CUTTING SPEED	BLADE LIFE
The Blade	Segment Bond Hardness	Harder Softer	Slower Faster	Longer Shorter
	Diamond Quality	Lower Higher	Slower Faster	Longer Shorter
	Diamond Concentration	Lower Higher	Slower Faster	Longer Shorter
	Segment Width	Thicker Thinner	Slower Faster	Longer Shorter
The Saw	Horsepower	Lower Higher	Slower Faster	Longer Shorter
	Blade Speed	Higher Lower	Slower Faster	Longer Shorter
The Job	Water Volume	Higher Lower	Slower Faster	Longer Shorter
	Cutting Depth	Deep Shallow	Slower Faster	Longer Shorter
	Cutting Pressure	Lower Higher	Slower Faster	Longer Shorter
The Material	Material Hardness	Harder Softer	Slower Faster	Longer Shorter
	Material Abrasiveness	Less More	Slower Faster	Longer Shorter
	Aggregate Size	Larger Smaller	Slower Faster	Longer Shorter
	Steel Reinforcing	More Less	Slower Faster	Longer Shorter

DIAMOND CUTTING TOOL FACTS

MAXIMUM BLADE CUTTING DEPTHS and OPERATING SPEEDS

Blade Diameter	Cutting Depth	Recommended Operating Speed (RPM)	Maximum Safe Speed (RPM)
12"	3-5/8"	3050	5100
14"	4-5/8"	2600	4300
16"	5-5/8"	2300	3800
18"	6-5/8"	2050	3400
20"	7-5/8"	1850	3050
24"	9-5/8"	1550	2550
26"	10-5/8"	1450	2350
30"	11-3/4"	1250	2040
36"	14-3/4"	1000	1700
42"	17-3/4"	860	1450
48"	20-3/4"	750	1275

Quickie Saw Blades

12"	4"	6300
14"	5"	5400

Wall Saw Blades

18"	6-1/2"	2050	3400
24"	9-1/2"	1550	2550
30"	11-1/2"	1250	2040
36"	14-1/2"	1000	1700
42"	17-3/4"	860	1450
48"	19-3/4"	750	1275

Masonry Saw Blades

14"	5"	3600	5400
18"	7"	2800	3400
20"	8"	2500	3050

Tile Saw Blades

6"	1-3/4"	6050	10175
7"	2-1/4"	5175	8725
8"	2-3/4"	4500	7650
9"	3-1/4"	4025	6800
10"	3-3/4"	3625	6125

Power Hand Saw Blades

4"	1"	9075	15000
4-1/2"	1-1/4"	8065	13300
5"	1-1/2"	7250	12000
7"	2-1/2"	5175	8725
8"	3"	4500	7650

RECOMMENDED CORE DRILLING SPEEDS

Bit Diameter	10 Amp Motor (RPM)	15 Amp Motor (RPM)	18 Amp Motor (RPM)	20 Amp Motor (RPM)
Up to 3"	1200	1200	1200	1200
4"	-	900	900	1200
5"	-	375	900	450
6"	-	375	375	450
7"	-	375	375	450
8"	-	-	375	450
10"	-	-	375	450
12"	-	-	375	450
14"	-	-	375	450

CORE BIT NOMENCLATURE

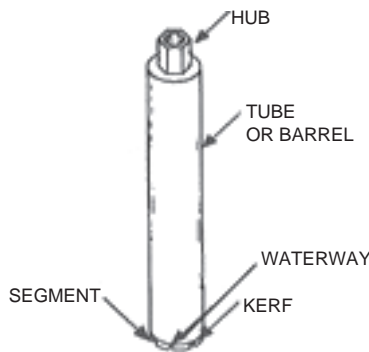

SEGMENT - Metal matrix containing diamonds which are brazed or welded to the tube.

WATERWAY - Allows cooling water to reach the cutting surface.

TUBE OR BARREL - Nominally 14" in length with a 13" core depth.

HUB - 1/2" to 1-1/2" threaded 5/8-11 1-5/8 and up threaded 1-1/4-7.

KERF - Width of segment. Normally .145"

CORE RIG NOMENCLATURE

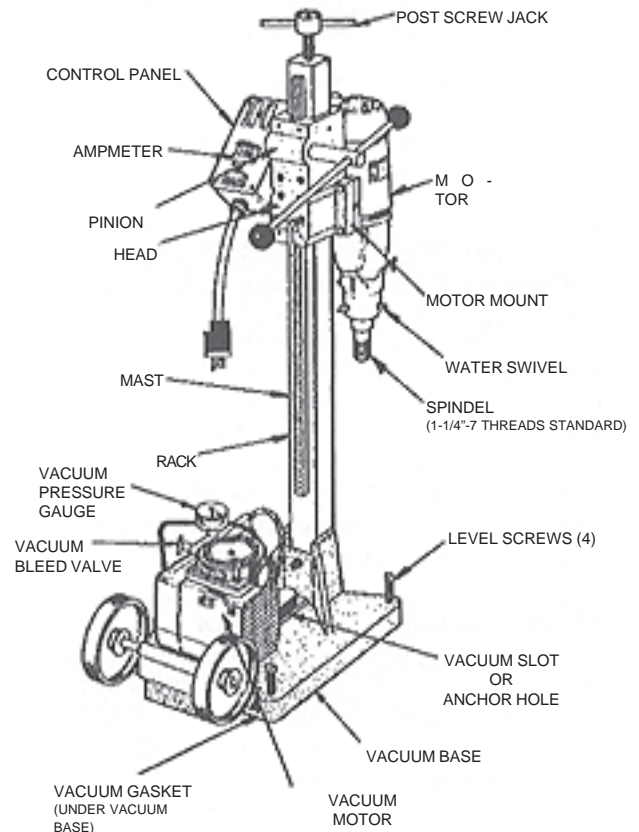

RECOMMENDED DRY HOLE SAW OPERATING SPEEDS

Bit Diameter	Min. AMPS	Max RPM/Min RPM
1"	6	6000/2300
1-1/4"	6	6000/2300
1-1/2"	7	5000/1600
1-3/4"	7	5000/1600
2"	7	5000/1200
2-1/4"	7	5000/1200
2-1/2"	7	5000/1200
3"	7	5000/800
3-1/2"	10	5000/800
4"	10	5000/700
5"	10	2500/700
6"	10	2500/600

A QUESTION OF QUALITY

DO YOU WANT TO KNOW THE PRICE OR HOW MUCH IT WILL COST?

WHICH BIT DO I BUY?



4"

PREMIUM

\$375

(is the price)

APPROXIMATE

LIFE IN FEET - **65**

COST PER INCH FOOT

$$= \frac{\$375}{65} = \$5.76 \text{ Per Ft.}$$

HOLES TO BE DRILLED

200 @ 8" (=133.2 Ft.)

= \$5.76 (Cost per Ft.) x 133.2

= **\$767.23 Cost of Bits**



4"

HEAVY DUTY

\$300

(is the price)

APPROXIMATE

LIFE IN FEET - **45**

COST PER INCH FOOT

$$= \frac{\$300}{45} = \$6.66 \text{ Per Ft.}$$

HOLES TO BE DRILLED

200 @ 8" (=133.2 Ft.)

= \$6.66 (Cost per Ft.) x 133.2

= **\$887.11 Cost of Bits**



4"

STANDARD DUTY

\$225

(is the price)

APPROXIMATE

LIFE IN FEET - **30**

COST PER INCH FOOT

$$= \frac{\$225}{30} = \$7.50 \text{ Per Ft.}$$

HOLES TO BE DRILLED

200 @ 8" (=133.2 Ft.)

= \$7.50 (Cost per Ft.) x 133.2

= **\$999.00 Cost of Bits**

WHICH BLADE DO I BUY?



12 X .125 X 20MM

PREMIUM

\$575 (is the price)

APPROXIMATE

LIFE IN INCH FEET - **10,000**

COST PER INCH FOOT

$$= \frac{\$575}{10,000} = .0575 \text{ ¢ Per In. Ft.}$$

INCH FEET TO BE CUT

25,000

= .0575 (Cost per In. Ft.) x 25,000

= **\$1437.50 Cost of Blades**



12 X .125 X 20MM

HEAVY DUTY

\$425 (is the price)

APPROXIMATE

LIFE IN INCH FEET - **6,500**

COST PER INCH FOOT

$$= \frac{\$425}{6,500} = .0654 \text{ ¢ Per In. Ft.}$$

INCH FEET TO BE CUT

25,000

= .0654 (Cost per In. Ft.) x 25,000

= **\$1635.00 Cost of Blades**



12 X .125 X 20MM

STANDARD DUTY

\$325 (is the price)

APPROXIMATE

LIFE IN INCH FEET - **4,500**

COST PER INCH FOOT

$$= \frac{\$325}{4,500} = .0722 \text{ ¢ Per In. Ft.}$$

INCH FEET TO BE CUT

25,000

= .0722 (Cost per In. Ft.) x 25,000

= **\$1805.00 Cost of Blades**

TROUBLE SHOOTING DIAMOND BLADES

BURNING



CAUSE: Insufficient coolant (water) at the cutting surface of a wet cut core bit or blade.

REMEDY: Increase the flow of water and check for proper direction of the water to the cutting surface.

CAUSE: Insufficient cooling (air)

REMEDY: Allow the blade to cool every few feet of cut by running it at full speed outside of the cut.

BLADE WILL NOT CUT (GLAZING)

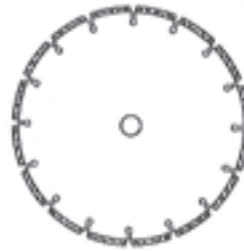

CAUSE: Blade is too hard for material being cut. (Wrong spec.) Bond will not wear away to expose new diamonds.

REMEDY: Choose a softer bond.

CAUSE: material being cut is too hard.

REMEDY: Dress or sharpen the blade with a soft concrete block or old abrasive wheel to expose new diamonds. If continual dressing is needed change to a softer bond.

CAUSE: Insufficient power to permit blade to cut properly.

REMEDY: Check and tighten belts and make sure adequate horsepower is available for application.

SEGMENT LOSS

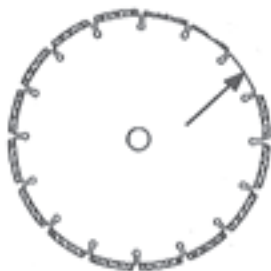

CAUSE: On stone or masonry blades the material may not have been held firmly which allowed the blade to twist or jam.

REMEDY: Material must be held firmly.

CAUSE: Overheating due to an inadequate supply of water. Look for burning or discoloration near missing segments.

REMEDY: Provide adequate supply of water.

CAUSE: Undercutting which wears away blade core and weakens the weld between segment and core.

REMEDY: Increase water supply and if material being cut is very abrasive switch to wear-resistant cores.

CAUSE: Blade is too hard for material being cut causing excessive dullness and the segment separates because of impact, fatigue or frictional heat.

REMEDY: Use the proper blade specification for material being cut.

WORN OUT-OF-ROUND

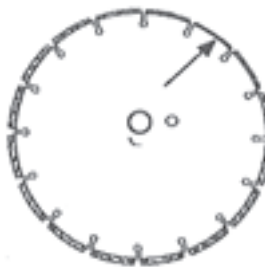

CAUSE: Worn shaft bearings on saw which allows blade to run eccentric.

REMEDY: Install new bearings.

CAUSE: Engine not properly tuned which causes "hunting".

REMEDY: Tune the engine.

CAUSE: Blade arbor hole is damaged.

REMEDY: If blade is in good condition the core may be re-bored.

CAUSE: Blade mounting arbor is worn or is the wrong size.

REMEDY: Replace worn arbor bushing or arbor shaft.

CAUSE: Bond is too hard for material causing machine to "pound" at regular intervals, thereby wearing one half of the blade more than the other.

REMEDY: Use a softer bond.

UNDERCUTTING

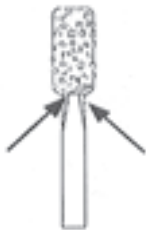

CAUSE: A condition in which the steel core wears at a faster rate than the diamond segments. It is caused by highly abrasive material grinding against the core.

REMEDY: The blade should be equipped with undercut protectors or polyarc segments.

ARBOR OUT OF ROUND



CAUSE: Blade collar is not properly tightened allowing it to turn or rotate on shaft.

REMEDY: Tighten collars.

CAUSE: Worn or dirty collars which do not allow proper blade clamping.

REMEDY: Clean and replace if necessary.

CAUSE: Blade not properly mounted.

REMEDY: Rebore arbor hole if within tolerances.

LOSS OF TENSION



CAUSE: Blade is used on misaligned saw.

REMEDY: Check for proper saw alignment.

CAUSE: Blade is excessively hard for the material being cut.

REMEDY: Correct bond spec.

CAUSE: Material slippage causing blade to twist.

REMEDY: Maintain a firm grip on material while cutting.

CAUSE: Undersize or mis-matched blade collars.

REMEDY: Minimum 3-7/8" - 4-1/2" on concrete saws, 6" minimum on blades over 30"

CAUSE: Blade used at improper RPM.

REMEDY: Check shaft RPM.

CAUSE: Improper mounting on arbor shaft allows collars to bend blade when tightened.

REMEDY: Make sure blade is securely on arbor shoulder until outside flange and nut are firmly tightened.

EXCESSIVE WEAR UNDERCUTTING

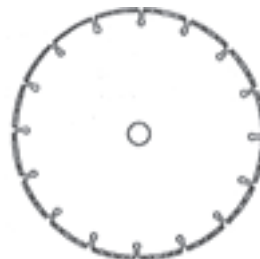

CAUSE: Using the wrong blade spec. on highly abrasive materials.

REMEDY: Change to a more abrasive resistant bond.

CAUSE: Lack of sufficient coolant to the blade often detected by excessive wear in the center of the segment.

REMEDY: Make sure water supply system is functioning properly.

CAUSE: Wearing out-of-round accelerates wear. Usually caused by bad bearings, loose or worn "V" belts.

REMEDY: Replace bad bearings or worn "V" belts.

TROUBLE SHOOTING DIAMOND BLADES

CORE CRACKS

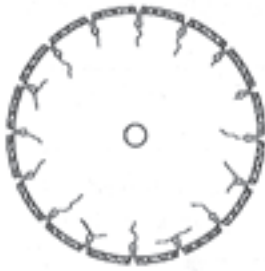

CAUSE: Blade is too hard for material being cut.
 REMEDY: Change to softer bond.
 CAUSE: Excessive cutting pressure, or jamming or twisting of the blade.
 REMEDY: The saw operator should use a steady even pressure without twisting the blade in the cut.
 CAUSE: Overheating through inadequate water supply or not allowing a dry blade to intermittently cool down.
 REMEDY: Use adequate water on wet cutting blades and allow adequate air flow on dry blades.

MISMOUNTING

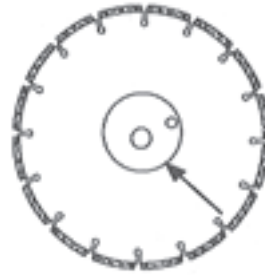

CAUSE: Blade collars are not properly tightened or are worn out.
 REMEDY: Check tightness and replace collars if necessary.

SEGMENT CRACKS



CAUSE: Blade is too hard for the material being cut.
 REMEDY: Use correct blade with a softer bond.

UNEVEN SIDE WEAR



CAUSE: Insufficient water, generally on one side of blade.
 REMEDY: Make sure water is being distributed evenly on both sides of blade.
 CAUSE: Equipment problem which causes blade to wear out of round.
 REMEDY: Replace bearings, worn arbor shaft or misaligned spindle.
 CAUSE: Saw head is misaligned.
 REMEDY: Check saw head alignment for squareness both vertically and horizontally.

TROUBLE SHOOTING CORE BITS

GLAZING

(Bit stops drilling or is very slow)



CAUSE: Too much feed pressure.
 REMEDY: Open bit with abrasive material (sand pot, concrete block, chop saw blade). Reduce feed pressure. Using an ammeter will help to control speed and pressure.
 CAUSE: Aggregate is too hard.
 REMEDY: Change to a softer bond.

LOST SEGMENTS

(Particularly on bits up to 1-3/4")



CAUSE: Steel reinforcing rod.
 REMEDY: Ease up on feed pressure (watch ammeter). Use a higher quality bit and increase the water flow.
 CAUSE: Not enough water to properly cool the bit.
 REMEDY: Increase water flow.
 CAUSE: Drill rig is not properly anchored.
 REMEDY: There are three ways of anchoring a core rig. **STANDING ON IT IS NOT ONE OF THEM!** This quick and dirty method damages the bit and the rig and dramatically slows the drilling process.

BENT SEGMENTS



CAUSE: Too much feed pressure and not enough water.
 REMEDY: Repair the bit if possible. Ease up on feed pressure and increase water flow.
 CAUSE: Aggregate is too hard.
 REMEDY: Change to a softer bond.

CORE HANGS UP

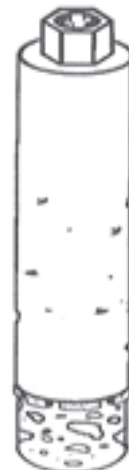

CAUSE: Not enough water to remove slurry.
 REMEDY: Remove bit and drive core out with a spike through the hub. Increase water flow.
 CAUSE: Core barrel is dented because of hammering on it to remove previous hung up cores.
 REMEDY: Repair the barrel. Increase water flow.

From the Booklet
“Introduction to Construction Products”
Published by
McCarthy Associates
RD#1 Box 34
Glen Rock, PA 17327



Reproduced & distributed with permission
of the copyright holder.